

# MP-2BM T-SERVO

## 3-Axis Servo Motor Type Packing Machine

### FEATURES

#### Machine Design:

- Cantilever build/ Heavy steel mainframe and housing, with integrated electrical cabinet. Robust steel frame servo-machine for multi-shift operation with high modularity
- Strict division between product/packaging material handling and drive elements.
- Minimum of mechanical parts and universality of the same parts where possible.
- Left and right hand version available.
- Box-motion type end sealer, featuring easy maintenance and hermetic sealing

#### Package Style:

- Taut or slack pillow pack with or without gusset fold.
- End fins: grooved longitudinally or transversely, with strait or zigzag cut.
- On request with print coding, carton insert, label or coupon, tear strip, tear notches and other easy opening features.

#### Packaging Material:

- Printed, print registered or non-printed, heat sealable or cold sealable monolayer or laminated film.

#### Smart Operation:

- The touch screen of the HMI panel is integrated on the top of the machine. As option also an adjustable panel mounted on a swivel arm is available. Parameter entry, errors, alarms, production statistics are all displayed on the HMI
- Smart functions: No product no pack/Misplaced item skip/Quick eye-mark locating/Speedy product change over

### SPECIFICATIONS

Packing type:	Pillow type (Center sealed type)
Film Width	Small: 380mm Medium: 580mm Large: >580mm
Product Size	Small: 50~150mm/L max. 130mm/W max. 50mm/H Medium: 150~400mm/L max. 230mm/W max. 80mm/H Large: >400mm/L max. 330mm/W >80mm/H
Speed & Output	(1)60-100packs/min (2)100-160packs/min(3)>160packs/min Product and film characteristics may affect machine output.
Cut Off Length	70mm-700mm(Standard range)
Power & Connection	Voltage: 3-phase, 220V-380V, 50/60Hz Air: 6 bar; 0.03~1m <sup>3</sup> /h for defect package reject and/or gusset folder
Machine Size & Weight	4700mm/L 1050mm/W 1670mm/H Approx.850kg

\*Remark: It may be designed & customized individually by KEED if the size of packing content is beyond the above size range

### MAIN APPLICATIONS



Breads



Cakes



Chocolates



Traycookies



10.4" Touch Panel  
Human Machine Interface

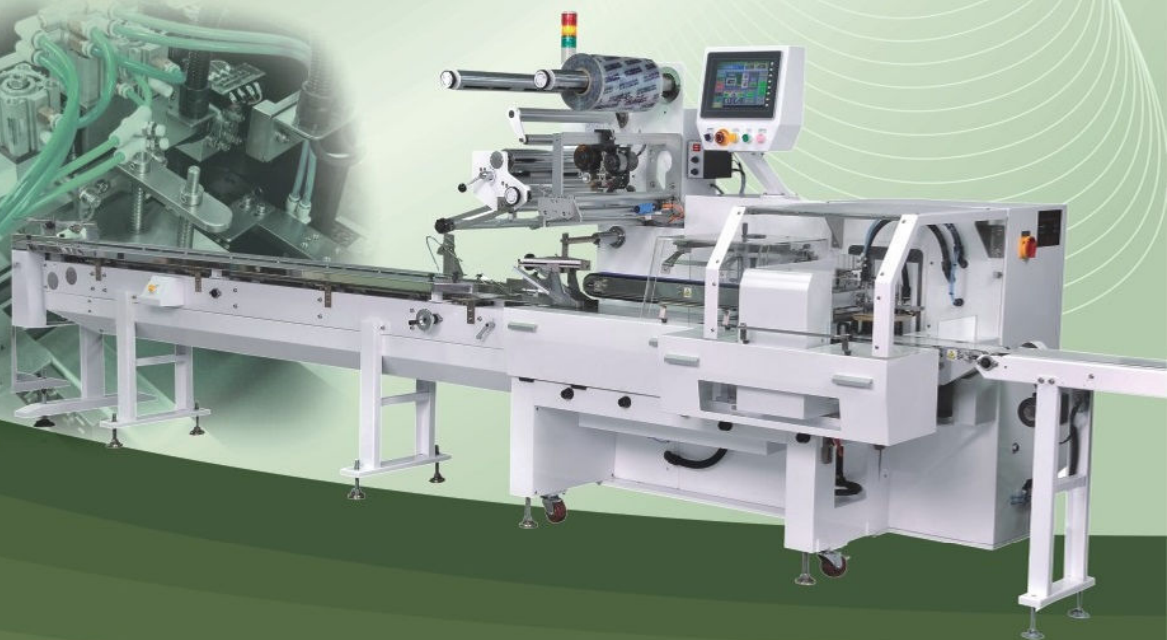

### Keed Automatic Package Machinery Co., Ltd.

NO.331-6, Lane106, Sec.7 Yen-ping North Road Taipei Taiwan  
TEL: +886-2-28105288 EXT: 26/27 FAX: +886-2-28102226 E-mail:service@keed.com.tw

Your Trustable Automation & Packaging Solution Provider

# MP-2BM T-SERVO

## 3-Axis Servo Motor Type Packing Machine

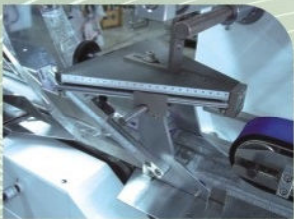
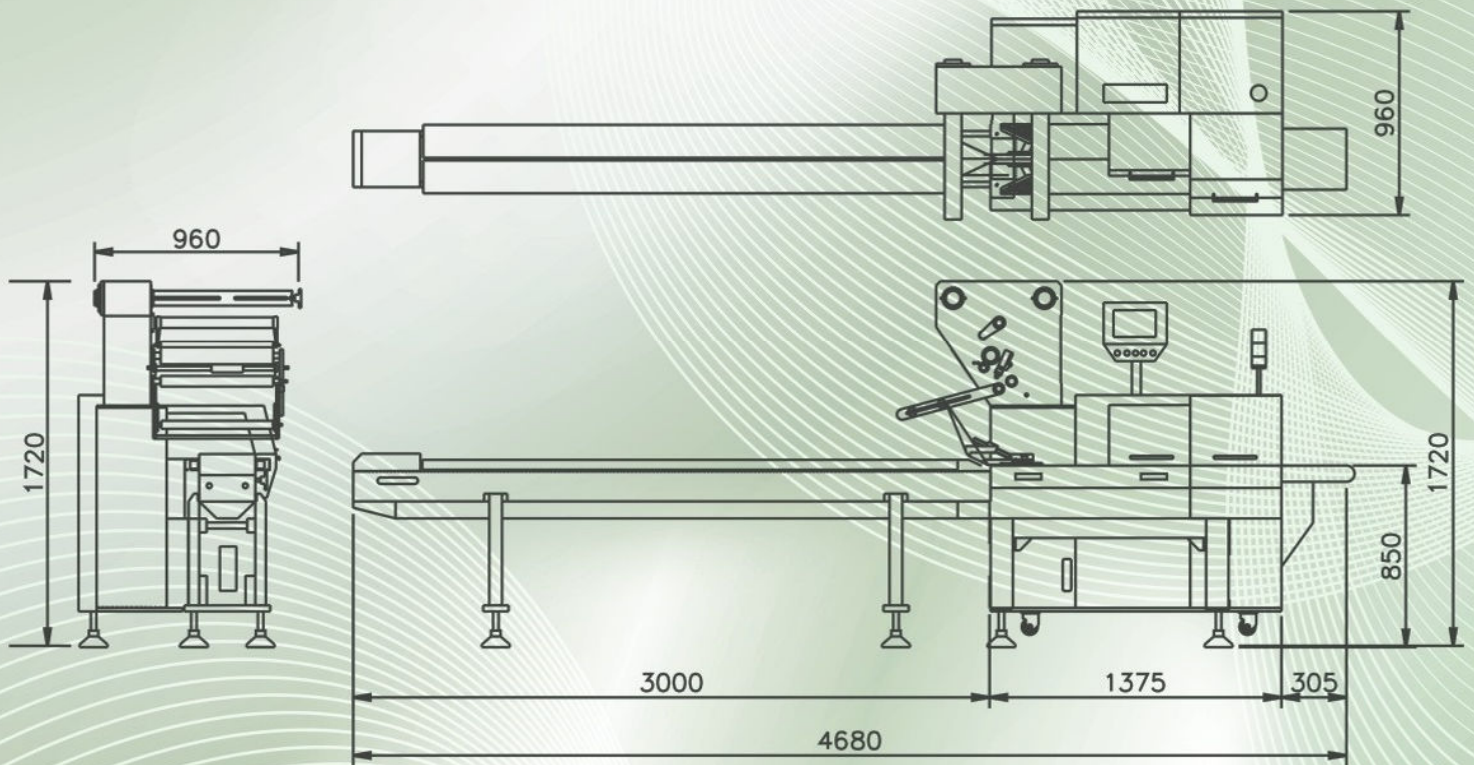

Adjustable Bag Former



Auto Feeder



Box-motion End Sealer



Double Film Holder



Heavy-duty Servo System



Safety Cover



HMI



SUS304

### OPTIONAL ACCESSORIES:

- ▶ Infeed conveyor family with a wide range of product specific functionalities
- ▶ Automatic product feeder & loader for high speed purpose
- ▶ Excess sealing areas trimming and trash collecting device
- ▶ Liquid pumping unit for napkins wetting purpose
- ▶ Stainless standard applied machine shell
- ▶ No product, no bag function
- ▶ Human machine interface
- ▶ Easy tear off cut device
- ▶ Automatic film splicer
- ▶ Labeling machine
- ▶ Perforator device
- ▶ Out-put collector
- ▶ Photocell sensor
- ▶ Gas flusher
- ▶ Date coder